



New Dimensions
in Motion

HITACHI LX100

Big Power, Balanced Distribution and Operating Ease Increase Productivity!

BEST MATCHING CONTROL (BMC) SYSTEM

- High power, sharp torque rise direct injection engine means superb digging power.
- Ideally balanced traction force and breakout force enhance productivity.
- Shift-down switch enhances efficient, powerful operation.
- High dumping clearance and reach for ease of loading onto large dump trucks.
- Extra long wheelbase and superb wide tread stability.
- Roomy and high visibility operator station with suspension seat for operator comfort.
- Monitoring/alarm system indicates the status of key machine functions.
- Hitachi's original power steering means outstanding maneuverability and high-speed straight-line travel.
- Large cross-section box-beam frame and strong loader frame for high durability.
- ORS (O-ring seal) hydraulic fittings and water-proof electric connectors for maximum reliability.
- Inboard wet disc brakes and sealed loader linkage pins greatly simplify maintenance with utmost reliability.

Shown with optional equipment

Rated Engine HP	85.8 kW (115 HP)
Operating Weight	10 705 kg (23 600 lb)
Bucket Capacity	1.5-2.3 m ³ (1.96-3.01 cu yd)



High Productivity and Reliability Built with Advanced Features!

BMC (Best Matching Control) System

High Performance

High power, sharp torque rise direct injection engine and ideally balanced traction force and breakout force enhance productivity.

High Ergonomic Standard

Optimally-matched to suit operator comfort for easy and safe operation.

High Reliability

The LX100 is feature-packed for high reliability and durability.



Shift-down Switch

The Hitachi LX100 wheel loader features swift, easy speed shifting for high productivity. Pressing the shift-down switch, located at the grip of the loader front control lever, reduces the travel speed automatically to the 1st speed in forward. Moving the lever to the reverse increases the speed automatically to 2nd gear. The result: the machine can instantly deliver the brute traction force for powerful digging and scooping up...with high operating efficiency.



Operator comfort

The operator station is designed and laid out for maximum comfort and efficiency. Fully adjustable suspension type seat and wide-adjustment tilt steering wheel reduce operator fatigue. Z-bar linkage eliminates dead space in forward visibility. There are plenty of work space and well arranged instruments, levers, and pedals. Vibration and noise are kept to a minimum.



Electronic Monitor

Hitachi's original monitoring system displays machine operating conditions and if an abnormal condition is found, this monitor gives an audible and visible warning to the operator.

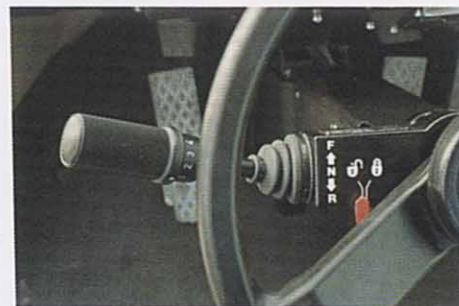

Comfortable Transmission Control Lever

Forward/reverse selection and speed changes can be smoothly done by one-lever control, without shocks. The fingertip control adds up to comfortable operation.



Easy Bucket Control

Light touch, hydraulic pilot control levers are designed for responsive and precise control. Two-lever, two-way type is standard while one-lever, four-way type is optional for operator choice. An optional port is available on the control valve for the special attachments.



ROPS Cab (Factory Option)

The ROPS cab is mounted on the shock-absorbing and sound-absorbing materials for operator comfort. Seat belt, cab pressurizer, heater and defroster are provided for comfortable operation. Air conditioner is available as factory option.



ROPS Canopy (Standard)

The operator's station is mounted through shock-absorbing rubbers to minimize vibration for operator comfort. To allow maximum operator comfort, all instruments are within easy view and reach.

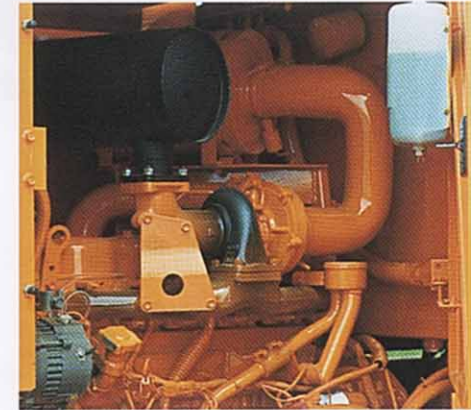

Isuzu 6BD1T

4-cycle, direct injection turbocharged diesel engine has high power to 85.8 kW (115 HP) and sharp torque rise for powerful operation.

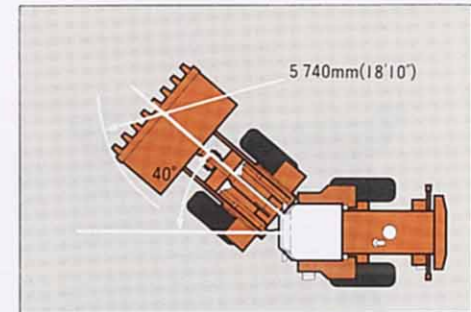

Small Turning Radius

Light-touch, full hydraulic power steering. 40-degree articulation to both right and left sides provides minimum turning radius of only 5 740 mm (18'10") measured at the outside corner of the bucket.

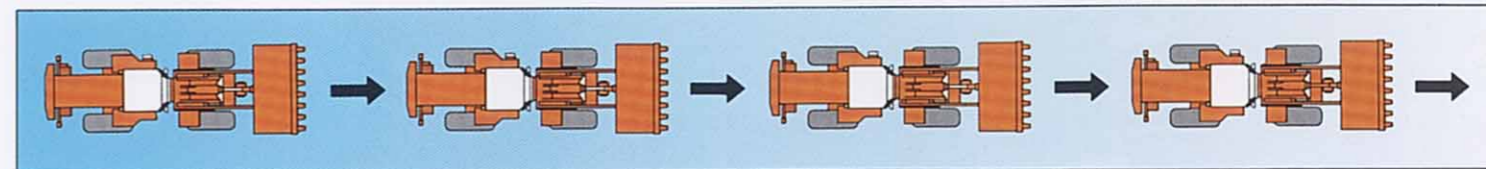

High-Speed Straight-Line Travel

Hitachi's original power steering mechanism, consisting of high-response priority valve* and orbit-roll, allows excellent high-speed straight-line travel and sharp turning. (* Diverts the oil flow to the steering circuit or the loader hydraulic circuit.)

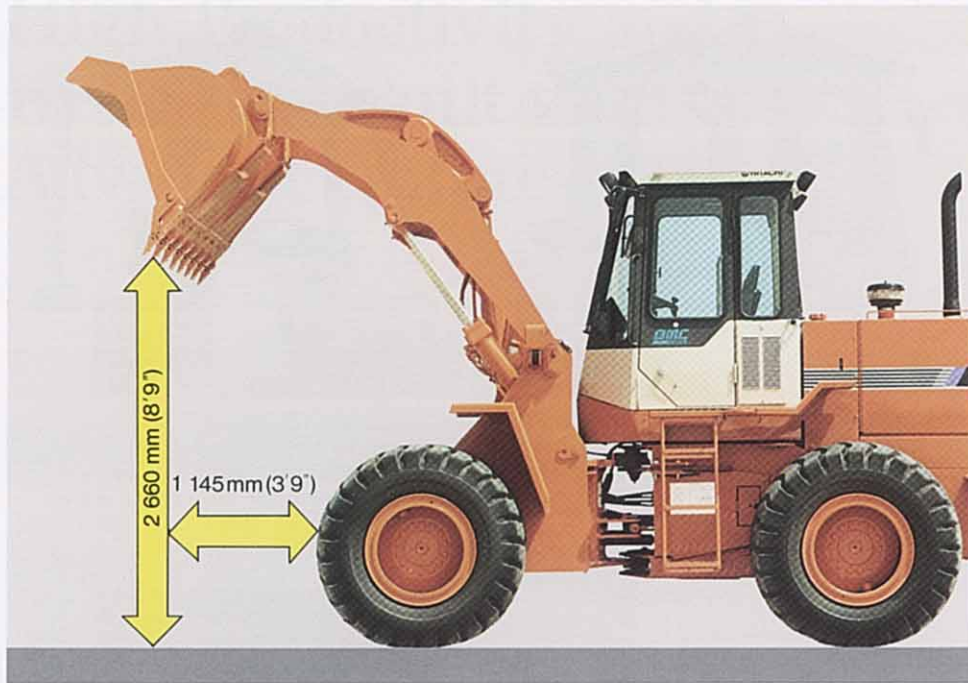

High Dumping Clearance

The high dumping clearance of 2 660 mm (8' 9") makes it easy to load materials onto large dump trucks. The large 46-degree tiltback angle of the bucket substantially reduces material spillage in load-and-carry operations with high efficiency.

Automatic Lift Arm Kickout

For efficiently repeated dumping at the same height, the lift arm kickout can automatically stop the lift arm at the preselected height. The lift arm kickout helps provide shorter cycle times and simplify the operator's job.

Bucket Positioner

The bucket positioner can automatically set the bucket into digging position. This lets the operator concentrate on steering and other operations.

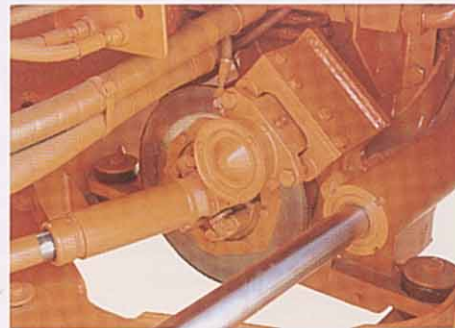

Reliable, Positive Spring-set Hydraulic-released Parking Brake

This parking brake is automatically applied with hydraulic pressure drop—for instance, engine stalling. The braking capacity is ample enough for high reliability.

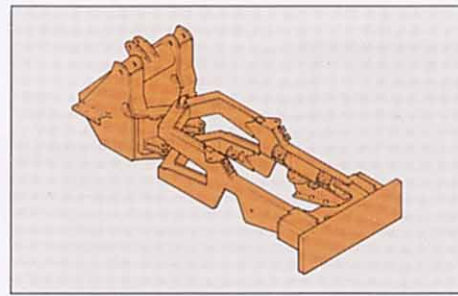

Rugged Main Frame

Large cross-section box-beam frame construction. Take a look at wide spread between the upper and lower hinges and the ample size of the plates that make up both of these hinges. These features show that Hitachi engineers design these critical joints for low stress and long life.

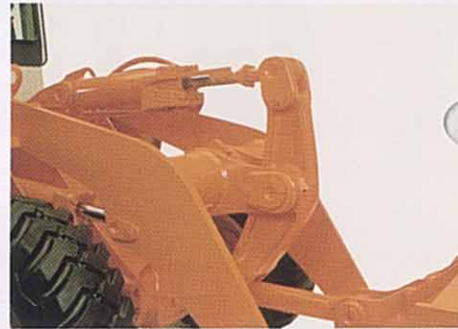

Hitachi's Original Z-bar Linkage

Hitachi's original Z-bar linkage provides high breakout force with short cycle times, and this linkage arrangement minimizes bucket angle change during lifting the arm operation for minimum material spillage.

Wide Loader Arm

High-strength, wide loader arm. This provides better visibility and makes the loader arm more resistant to arm twisting when loading the bucket corner. The LX100 utilizes a welded box tube which spreads the loading forces throughout the arm, increasing arm rigidity, and eliminating high stress concentration.

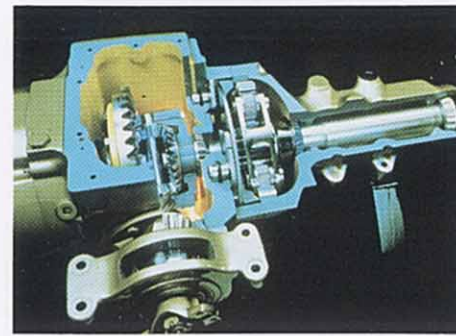

Inboard Wet Disc Brakes

Long-life, adjustment-free wet disc brakes are packed in the final drive, efficiently keeping brake discs cool for maximum durability.

High Stability

Rear axle oscillates ±13 degrees to keep all wheels in ground contact. Long wheel base and wide tread provide additional stability and ample tipping load for load-and-carry operation.



Reliable Hydraulic/Electric Lines

ORS (O-Ring Seal) and water-proof electric connectors ensure hydraulic/electricline reliability.

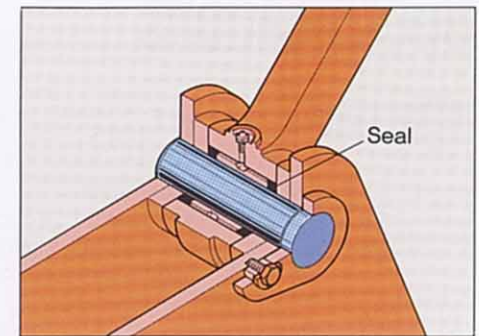

Reduced Maintenance Time

Z-bar linkage reduces number of joint pins. Chrome-plated pins are used with dust seals for extended service life and reduced maintenance time.

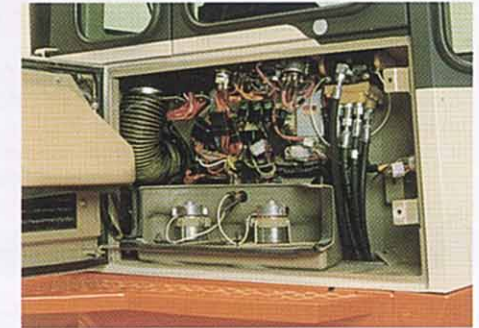

Centralized Electrical System

The electrical system is designed to locate all main harnesses at one distribution center. Almost all electrical diagnostic works can be done here.



Specifications

ENGINE

Model Isuzu 6BD1T
 Type Water-cooled, 4-cycle, 6-cylinder in-line, direct injection chamber type, turbo-charged diesel engine

Rated flywheel horsepower
 DIN* 6271, net 86.1 kW (117 PS) at 2 200 min⁻¹ (2 200 rpm)
 SAE** J1349, net 85.8 kW (115 HP) at 2 200 min⁻¹ (2 200 rpm)

* Deutsche Industrie Norm (German Industrial Standards)
 ** Society of Automotive Engineers (USA)

Maximum torque 490 N·m (50.0 kgf·m, 362 lbf·ft) at 1 400 min⁻¹ (1 400 rpm)

Piston displacement 5.79 l (353 cu in)
 Bore and stroke 102 mm × 118 mm (4.0" × 4.6")
 Starting system 24 V/4.5 kW electric motor starting
 Batteries 2 × 12 V/80 AH
 Air cleaner Dry type air cleaner with evacuator valve and double elements

TRANSMISSION

3-element, single-stage, single-phase torque converter. Full power-shift, countershaft type transmission.
 Modulating function assures shockless acceleration/deceleration and directional change without braking. Neutral start system prevents accidental starts.

Travel speeds with 17.5-25-12PR (L-3) tires:

	Forward	Reverse
1st	0-6.8 km/h (0-4.2 mph)	0-6.8 km/h (0-4.2 mph)
2nd	0-11.3 km/h (0-7.0 mph)	0-11.3 km/h (0-7.0 mph)
3rd	0-25.7 km/h (0-16.0 mph)	0-25.7 km/h (0-16.0 mph)
4th	0-39.5 km/h (0-24.5 mph)	

AXLE AND FINAL DRIVE

4-wheel drive system. A semi-floating front axle is fixed to the front frame.

Center-pin-supported, semi-floating rear axle provides total oscillation of ±13°. A spiral bevel gear for reduction and a single-reduction planetary gear on each wheel. Conventional differentials are standard. Optional NoSPIN differential on front axle is recommended for slippery underfoot conditions.

BRAKES

Service brakes: Power hydraulic inboard-mounted, wet disc brakes actuate all 4 wheels. 2 pedals are provided: the right for service braking and the left for braking and neutralizing.

Parking brake: Spring apply, hydraulic release dry disc brake mounted on the transmission front output shaft.

TIRES

Front and rear: 17.5-25-12PR (L-3) tubeless
 Rims: 25 × 14.00

STEERING SYSTEM

Center-pivot frame articulation. Full-hydraulic power steering. Articulation angle of 40° to each side for a minimum turning radius of 5 740 mm (18'10"), measured at the outside corner of the bucket. (with teeth)

MAIN FRAME

Front and rear high-strength frames of welded box construction, linked by hardened steel pins and upper spherical bearing and lower plane bearing.

FRONT-END ATTACHMENTS

Z-bar linkage provides superior breakout force and fast cycle times. Lift arm, linkage and bucket are made of high-tensile steel. Chrome-plated joint pins with dust seals for extended pin life and greasing intervals.

BUCKET CONTROLS

Control levers are hydraulic pilot control type, that features responsive and precise control. 2-lever type is standard and 1-lever type is optional.

Lift arm: Positions...Raise, Hold, Lower and Float.

Automatic kickout at full lift height. (Height adjustable)

Bucket: Positions...Tilt, Hold and Dump. Automatic bucket positioner adjustable to desired loading angle. No visual spotting required.

Cycle time with rated load in bucket:

Raise 5.9 sec
 Dump 1.4 sec
 Lower (empty bucket) 3.4 sec

HYDRAULIC SYSTEM

PUMP FOR LOADER AND STEERING

Pump 1 gear pump
 Max. oil flow 175 l/min (46.2 US gpm, 38.5 Imp gpm)

Relief valve setting:

Loader operations 19.6 MPa (200 kgf/cm², 2 840 psi)
 Steering 18.1 MPa (185 kgf/cm², 2 630 psi)

HYDRAULIC CYLINDERS

High-strength piston rods and tubes.

Dimensions:

	Q'ty	Bore	Rod dia.
Lift arm	2	125 mm (4.9")	63 mm (2.5")
Bucket	1	140 mm (5.5")	63 mm (2.5")
Steering	2	70 mm (2.8")	40 mm (1.6")

SERVICE REFILL CAPACITIES

	Liter	US gal	Imp gal
Fuel tank	200	52.8	44.0
Engine coolant	26	6.87	5.72
Engine oil	21.5	5.68	4.73
Torque converter & Transmission	9.5	2.51	2.09
Front axle	16	4.23	3.52
Rear axle	16	4.23	3.52
Hydraulic tank	76	20.1	16.7
Hydraulic system	100	26.4	22.0

OPERATING WEIGHT

Operating weight: 10 705 kg (23 600 lb), including rated capacity of lubricants, coolant, full fuel tank, 17.5-25-12PR (L-3) tubeless tires, 1.7 m³ (2.22 cu yd) capacity bucket, ROPS canopy, operator and other standard equipment.



DIMENSIONS

Equipped with 17.5-25-12PR (L-3) tubeless tires and 1.7 m³ (2.22 cu yd) bucket

Unit: mm (ft in)

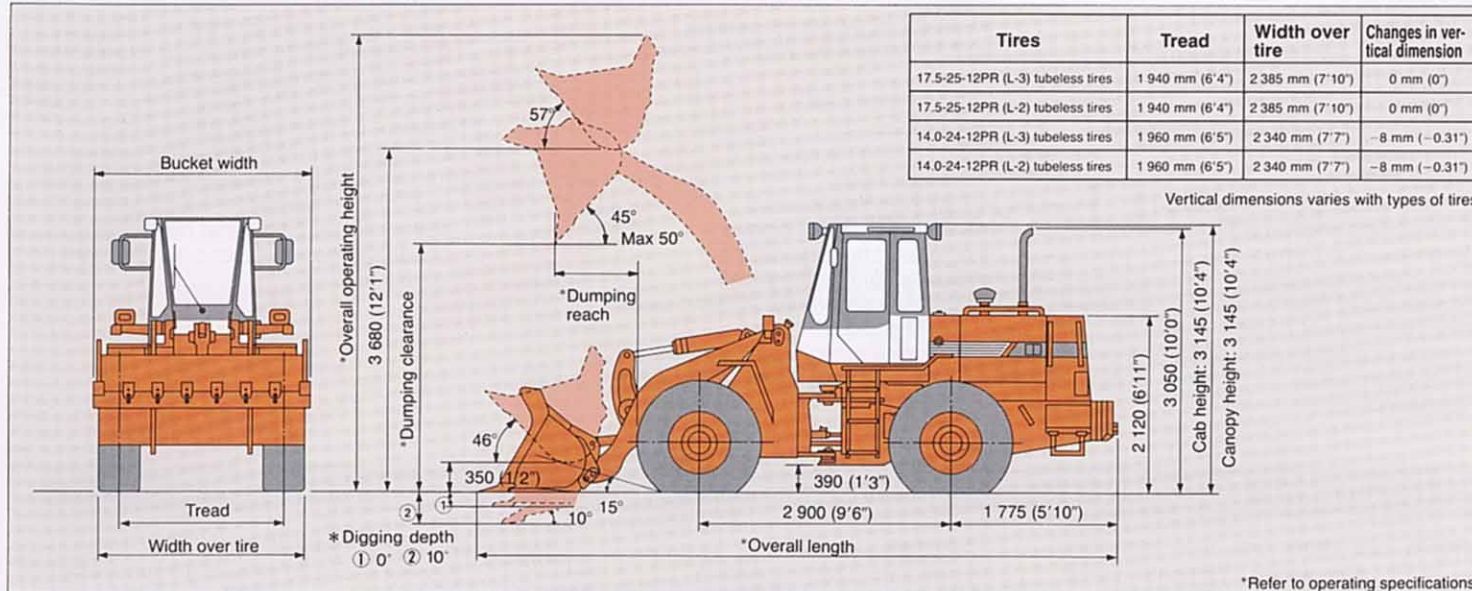

SPECIFICATIONS

Bucket type	Stockpiling		Stockpiling/Excavation	
	With teeth	With Bolt-on cutting edges	With teeth	With Bolt-on cutting edges
Bucket capacity	SAE heaped (2 : 1) 1.9 m ³ (2.49 cu yd)	2.0 m ³ (2.62 cu yd)	1.7 m ³ (2.22 cu yd)	1.8 m ³ (2.35 cu yd)
	Struck 1.62 m ³ (2.12 cu yd)	1.70 m ³ (2.22 cu yd)	1.44 m ³ (1.88 cu yd)	1.52 m ³ (1.99 cu yd)
Dumping clearance at max. height and 45° dump angle	2 610 mm (8'7")	2 675 mm (8'9")	2 660 mm (8'9")	2 730 mm (8'11")
Reach at 2 130 mm (7'0") height and 45° dump angle	1 545 mm (5'1")	1 510 mm (4'11")	1 525 mm (5'0")	1 490 mm (4'11")
Reach at max. height and 45° dump angle	1 195 mm (3'11")	1 125 mm (3'8")	1 145 mm (3'9")	1 040 mm (3'5")
Reach with arm horizontal and bucket level	2 400 mm (7'10")	2 295 mm (7'6")	2 325 mm (7'8")	2 220 mm (7'3")
Digging depth	Bucket horizontal 106 mm (4.2")	131 mm (5.2")	106 mm (4.2")	106 mm (4.2")
	10° digging angle 370 mm (1'3")	340 mm (1'1")	350 mm (1'2")	320 mm (1'1")
Overall operating height	4 940 mm (16'2")	4 940 mm (16'2")	4 900 mm (16'1")	4 900 mm (16'1")
Overall length	Bucket on ground 7 200 mm (23'7")	7 030 mm (23'1")	7 125 mm (23'5")	7 025 mm (23'1")
	Bucket in carry position 7 130 mm (23'5")	6 990 mm (22'11")	7 080 mm (23'3")	7 000 mm (23'0")
Turning radius (outside corner of bucket carry position)	5 760 mm (18'11")	5 745 mm (18'10")	5 740 mm (18'10")	5 710 mm (18'9")
Static tipping load*	Straight 7 640 kg (16 800 lb)	7 580 kg (16 700 lb)	7 670 kg (16 900 lb)	7 610 kg (16 800 lb)
	Full 40° turn 6 560 kg (14 500 lb)	6 500 kg (14 300 lb)	6 590 kg (14 500 lb)	6 530 kg (14 400 lb)
Breakout force	102 kN (10 380 kgf, 22 900 lbf)	94.5 kN (9 640 kgf, 21 300 lbf)	109 kN (11 150 kgf, 24 600 lbf)	101 kN (10 300 kgf, 22 700 lbf)
Operating weight*	10 740 kg (23 680 lb)	10 780 kg (23 770 lb)	10 705 kg (23 600 lb)	10 745 kg (23 690 lb)

Notes: 1. All dimensions, weight and performance data based on SAE J732 FEB80 and J742 FEB85 Standards.

2. Static tipping load and operating weight marked with * include 17.5-25-12PR (L-3) tires (no ballast) with lubricants, coolant, full fuel tank, ROPS canopy and operator. Machine stability and operating weight depend on counterweight, tire size and other attachments. Compensate operating weight and static tipping load with weight changes listed below.

WEIGHT CHANGES

Tires and options	Change in operating weight	Change in tipping load	
		Straight	Full 40° turn
17.5-25-12PR (L-3) tubeless tires	0	0	0
17.5-25-12PR (L-2) tubeless tires	-60 kg (-130 lb)	-40 kg (-90 lb)	-35 kg (-80 lb)
14.0-24-12PR (L-3) tubeless tires	-170 kg (-375 lb)	-115 kg (-255 lb)	-110 kg (-240 lb)
14.0-24-12PR (L-2) tubeless tires	-170 kg (-375 lb)	-115 kg (-255 lb)	-110 kg (-240 lb)
ROPS cab (in lieu of ROPS canopy)	+145 kg (+320 lb)	+140 kg (+310 lb)	+130 kg (+290 lb)
Bucket teeth (removed)	-110 kg (-240 lb)	+130 kg (+285 lb)	+125 kg (+275 lb)
Bolt-on cutting edges (in lieu of bolt-on teeth)	+40 kg (+90 lb)	-45 kg (-100 lb)	-40 kg (-90 lb)
2nd counterweight	+420 kg (+925 lb)	+950 kg (+2 095 lb)	+780 kg (+1 720 lb)

STANDARD EQUIPMENT

Since standard equipment may vary by country, so please consult your Hitachi dealer for details.

- Engine
- Alternator (24 V-50 A)
- Dry type air cleaner (dual element)
- Powershift transmission (4 fwd/3 rev)
- Conventional differentials
- Full hydraulic power steering
- Front and rear fenders
- ROPS canopy
- Front and rear working lights (4)
- Turn signals and hazard lamps
- Rearview side mirrors
- Tilt type steering wheel
- Standard tool kit
- Electric starter (4.5 kW)
- Engine preheater (glow plug)
- Shift-down switch
- Torque converter
- 4-wheel drive system
- Wet disc type service brakes
- 17.5-25-12PR (L-3) tubeless tires
- Horn
- Suspension seat
- Headlights (2)
- Stop and tail lamps (2)
- Drawbar hitch
- 2-spool hydraulic valve
- Automatic lift arm kickout
- Automatic bucket positioner
- Monitoring/alarm system
 - Audible and visible warning system
 - "Stop group"
 - Engine oil pressure, engine coolant temperature, brake pressure, and parking brake.

"Caution group"

Alternator charge, air cleaner clogging, parking brake, engine oil filter clogging, hydraulic oil filter clogging and transmission oil pressure.

○ Gauges and pilot lamps

Engine coolant temperature gauge, transmission oil temperature gauge, fuel level gauge, hourmeter (right console), speedometer, turn signal pilot lamps, headlight pilot lamps and working light pilot lamps.

OPTIONAL EQUIPMENT

- ROPS cab (front and rear windshield washers and wipers, cigarette lighter, astray, floor mat, interior rearview mirror, cab-mounted working lights, heater, defroster and cab pressurizer)
- Air conditioner (factory option) (Not attachable with ROPS canopy)
- Seat belt
- Emergency steering system
- Lockable covers (Not attachable with ROPS cab)
- Backup alarm
- 2nd counterweight (Not applicable with ballasted tires)
- Additional hydraulic equipments
3-spool hydraulic valve kit (3-spool valve, control lever, hoses and pipings)

WORKING EQUIPMENT

- Bucket (with skid shoes)

Bucket type	Capacity*	Width	Weight
Stockpiling w/bolt-on teeth	1.9 m ³ (2.49 cu yd)	2 460 mm (8'1")	960 kg (2 120 lb)
Stockpiling w/bolt-on cutting edges	2.0 m ³ (2.62 cu yd)	2 460 mm (8'1")	1 000 kg (2 200 lb)
Stockpiling/Excavation w/bolt-on teeth	1.7 m ³ (2.22 cu yd)	2 460 mm (8'1")	924 kg (2 040 lb)
Stockpiling/Excavation w/bolt-on cutting edges	1.8 m ³ (2.35 cu yd)	2 460 mm (8'1")	964 kg (2 130 lb)

*SAE heaped

- Light-duty bucket: 2.3 m³ (3.01 cu yd)
- Multi-purpose bucket: 1.5 m³ (1.96 cu yd)
- Bucket teeth
- Log grapple
- Dumping fork
- Tires: 17.5-25-12PR (L-3) tubeless
17.5-25-12PR (L-2) tubeless
14.0-24-12PR (L-3) tubeless
14.0-24-12PR (L-2) tubeless
- Cutting edges (not applicable with bucket teeth)
- Lumber grapple
- Lumber fork

BUCKET SELECTION GUIDE

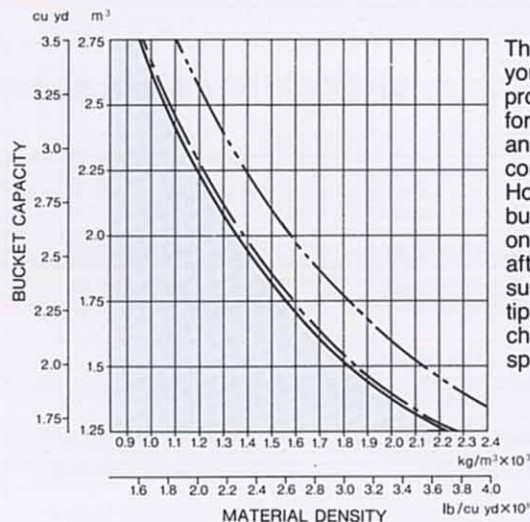

This guide will help you in selecting proper bucket size for material density and loader configurations. However, specific bucket size should only be determined after adding or subtracting all the tipping load changes due to specifications.

— : Standard ROPS canopy
 - - - : ROPS cab in lieu of ROPS canopy
 ····· : ROPS cab in lieu of ROPS canopy & 2nd counterweight

These specifications are subject to change without notice. Illustrations may or may not include optional equipment and accessories, and all standard equipment.

Hitachi Construction Machinery Co., Ltd.

Head Office: Nippon Bldg., 6-2, 2-chome, Ohtemachi,
Chiyoda-ku, Tokyo, 100 Japan
 Telephone: Tokyo (03) 3245-6377
 Facsimile: Tokyo (03) 3246-2609
 Telex: J32539 HITACONJ
 Cable Address: "TOKHITACHIKENKI"