

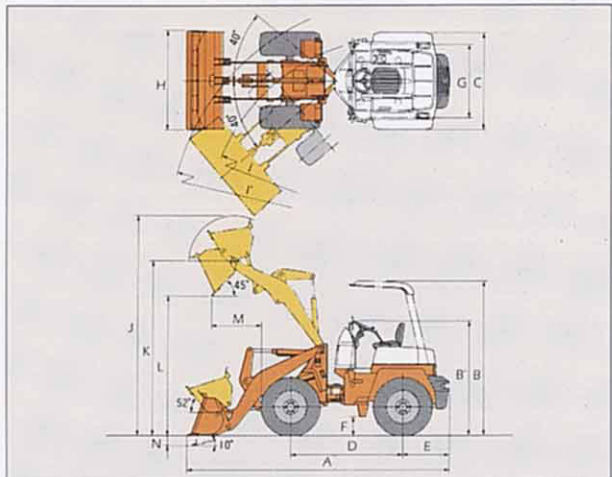

## DIMENSIONS

Unit: mm



	LX20-2	LX30-2
A Overall length	4 025 (13' 2")	4 480 (14' 8")
B Overall height with canopy	2 465 (8' 1")	2 655 (8' 9")
Overall height with cab	2 470 (8' 1")	2 650 (8' 8")
B' Overall height	1 860 (6' 1")	1 955 (6' 5")
C Overall width	1 505 (4' 11")	1 655 (5' 5")
D Wheel base	1 750 (5' 9")	1 950 (6' 5")
E Overhang	770 (2' 6")	800 (2' 7")
F Ground clearance	225 (8.9")	315 (12.4")
G Tread width	1 180 (3' 10")	1 260 (4' 2")
H Bucket width	1 570 (5' 2")	1 690 (5' 7")
I Turning radius (outside corner of bucket carry position)	3 595 (11' 10")	4 005 (13' 2")
J Overall operating height	3 405 (11' 2")	3 790 (12' 5")
K Height to hinge pin-fully raised	2 675 (8' 9")	3 000 (9' 10")
L Dumping clearance at max. height & 45° dump angle	2 140 (7' 0")	2 415 (7' 11")
M Reach at max. height & 45° dump angle	785 (2' 7")	815 (2' 8")
N Digging depth (10° digging angle)	150 (5.9")	170 (6.7")

Note: Equipped with B.O.C. stockpile bucket.

## SE SPECIFICATIONS

		LX20-2	LX30-2
Bucket capacity (SAE heaped)	m <sup>3</sup> (yd <sup>3</sup> )	0.4 (0.52)	0.5 (0.65)
Operating weight	kg (lb)	2 520 (5 560)	3 300 (7 280)
Lift arm raise	sec	4.5	4.8
Lift arm lower	sec	2.8	3.0
Bucket dump	sec	1.0	
Travel speed Travel/Work	km/h (mph)	15.0/7.0 (9.3/4.3)	
Transmission F/R		2/2	
Max. traction force	kN (kgf, lbf)	24.5 (2 500, 5 510)	31.9 (3 250, 7 170)
Breakout force	kN (kgf, lbf)	25.0 (2 550, 5 620)	32.4 (3 300, 7 270)
Max. articulation angle	deg	40	
Make & model		Isuzu 3LD1	Yanmar 3TNE84T
Type		Swirl	Direct, Turbocharged
Engine	Rated horsepower (DIN 6271, net)	kW/min <sup>-1</sup> (PS/rpm)	21.3/2 400 (29.0/2 400)
	Rated horsepower (SAE J1349, net)	kW/min <sup>-1</sup> (HP/rpm)	21.3/2 400 (28.6/2 400)
	Piston displacement	L (in <sup>3</sup> )	1.50 (91.5)
Drive system		2-mode HST (Travel/Work)	
Service brake		Dry disc type	Wet disc type
Parking brake		Dry disc type	
Oscillation		Frame oscillation	Rear axle oscillation
Tire size		12.5/70-16-6PR (L2)	15.5/70-18-8PR (L2)
Fuel tank	L (US gal, Imp gal)	35 (9.2, 7.7)	50 (13.2, 11.0)
Engine oil (exchange)	L (US gal, Imp gal)	6 (1.6, 1.3)	5.5 (1.5, 1.2)
Hydraulic tank	L (US gal, Imp gal)	32 (8.5, 7.0)	42 (11.1, 9.2)

Note: Equipped with B.O.C. stockpile bucket.

## SE STANDARD EQUIPMENT

- General purpose bucket (with bolt on cutting edge) 0.40 m<sup>3</sup> for LX20-2
- General purpose bucket (with bolt on cutting edge) 0.50 m<sup>3</sup> for LX30-2
- Monitor panel • Foot-operated parking brake pedal
- Front attachment control lever lock • Transmission shift lever lock
- Floor mat • Seat cover • Neutral start system • 2-spool control valve
- Halogen headlights • Hazard lamps

## OE OPTIONAL EQUIPMENT

- Light duty bucket 0.46 m<sup>3</sup> for LX20-2 • Light duty bucket 0.6 m<sup>3</sup> for LX30-2
- Bucket teeth • Lumber fork • Canopy • ROPS cab
- 4-pillar canopy with front glass • 3-spool control valve • Back alarm
- Tire chain

These specifications are subject to change without notice. Illustrations may or may not include optional equipment and accessories, and all standard equipment.